

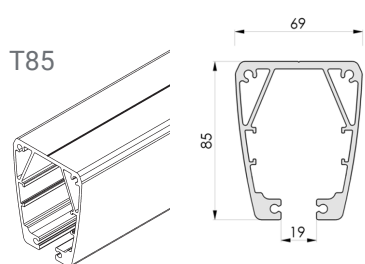

TRACKS FOR LUNA[®] CEILING LIFT

Discreet and elegant tracks for ceiling and wall mounting, made from recycled aluminum.



WinnCare's track systems represent a whole world of flexible, robust tracks that are easy to install. We offer a wide range of track systems that meet the varying and challenging needs of today's healthcare sector.

The small and strong low-profile track, T85, at 85 mm, has a low weight and optimal span and is easy to install.

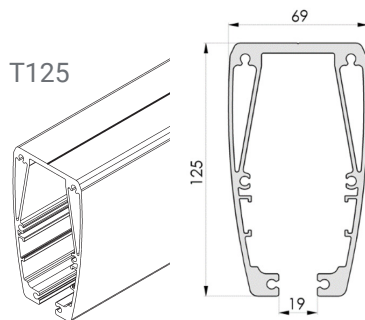

The T125 track, at 125 mm, has the largest span of all WinnCare tracks and can be used as a continuous track together with our unique transition gate.

The E-track is unique because it is a wall-mounted track solution. The E-track is a flat and discreet wall track and a preferred alternative to the wall and ceiling mounts commonly used. Additionally, the E-track is easy and quick to install, making it the preferred choice for home care and institutions.

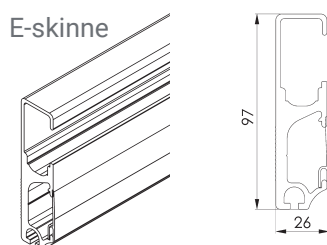

Regardless of the system setup requirements, all WinnCare tracks can work together as a total solution, ensuring easy installation and use.

ITEM NUMBERS

Model	Length	Item no.
T85	4,3 m	016-01271
T85	5,5 m	016-01272
T85	7 m	016-01273
T125	4,3 m	016-01276
T125	5,5 m	016-01277
T125	7 m	016-01278
E-track	4,3 m	016-01028
E-track	5,5 m	016-01029
E-track	7 m	016-01027

ACCESSORIES

If you need a room-to-room solution or if two tracks need to cross each other, WinnCare offers a selection of accessories, including:

- Switch track
- Powered turntable
- Transition gate (electric or manual)
- e-Station (track with built-in charging function)



HIGHLIGHTS

- Can be mounted on the ceiling or wall.
- Discreet and easy to install in various setups.
- The profiles can be combined to optimize solutions.
- Clean and simple design.



SUSTAINABLE PATIENT TRANSFER

Our tracks are made from recycled aluminum consisting of 75% recycled post-consumer aluminum scrap, extruded using 100% renewable energy.

By manufacturing our tracks from this type of aluminum, we can reduce our CO2 emissions by up to 66% on a standard track setup at scope 3 level, thereby contributing to a greener and more sustainable future.

For further specifications, contact info@winncares.dk. All figures and measurements are indicative and may vary in certain use situations. Winncares reserves the right to make changes without prior notice. The images may contain accessories. Please contact info@winncares.dk for more information.

CE MDD93/42/EEC
Class I

FOR FURTHER INFORMATION, PLEASE CONTACT

winncares.com
E-mail: info@winncares.dk
Telefon: +45 70273720



WIN  CARE