

WINN CARE

F r a n c e

4 Le Pas du Château
85670 SAINT PAUL MONT PENIT

TEL : +33 (0)2 51 98 55 64

FAX : +33 (0)2 51 98 59 07

Email : info@medicatlantic.fr

Site Internet : <http://www.winncare.fr>

USER'S MANUAL Mobility Support Systems



**A649-00 / A650-00
SAM Ergonom**

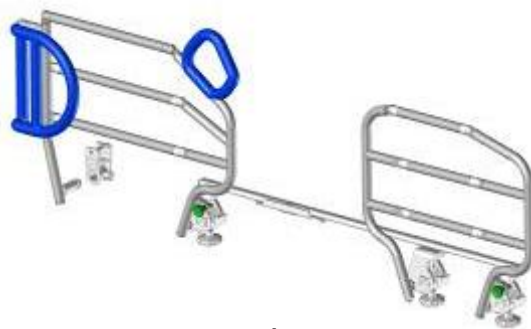

**A647-00 / A648-00
SAM Ergonom plus**



**A651-00 / A652-00
SAM Ergonom light**



**A618-00 / A619-00
SAM Ergonom**

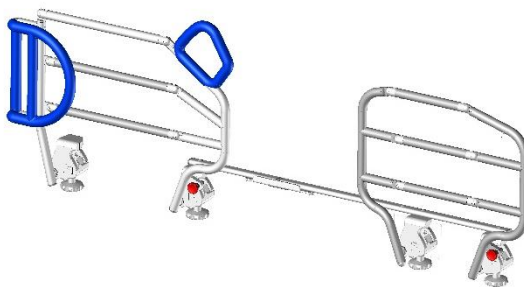

**A614-00 / A615-00
SAM Ergonom plus**



**A628-00 / A629-00
SAM Ergonom light**

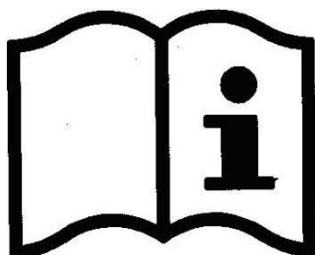

Avec Ecofolio
tous les papiers
se recyclent.

1. TRANSPORT CONDITIONS	3
2. STORAGE CONDITIONS	3
3. ASSEMBLY CONDITIONS	4
3.1. ASSEMBLING OF THE SIDERAILS A614-00/A615-00 A618-00/A619-00 A628-00/A629-00	5
3.2. ASSEMBLING OF THE SIDERAILS A647-00/A648-00 A649-00/A650-00 A651-00/A652-00	6
4. CONDITIONS FOR USE	7
4.1. FUNCTION	7
4.2. USE	8
4.3. PRECAUTIONS FOR USE	9
4.4. RESIDUAL RISKS	9
5. MAINTENANCE CONDITIONS	9
5.1. IDENTIFICATION	9
5.2. UPKEEP	10
5.3. CLEANING	10
5.4. DISINFECTION	10
5.4.1. OBJECTIVE	10
5.4.2. INDICATION	10
5.4.3. EQUIPMENT	10
5.4.4. TECHNIQUE	10
5.5. LIFETIME	11
5.6. WARRANTIES	11
6. CONDITIONS FOR SCRAPPING	11

Dear Sir/Madam,

You have acquired a WINNCARE medical accessory, and we thank you for your custom.

Our medical support systems (MSSs) and their accessories are designed and manufactured in compliance with the essential requirements applicable thereto of European Directives 2007/47/EC.

They are tested in conformity with standard EN 60601-2-52 (2010) in their commercial configurations, including the boards and accessories that we manufacture, so as to ensure you maximum safety and performance.

As a result, maintenance of the contracted good's warranty depends on compliance with the conditions for use recommended by WINNCARE and the use of original boards and accessories, which also guarantees you safe use of the medical MSS and its accessories.

1. TRANSPORT CONDITIONS

During transport, the mobility support system must be strapped and protected by plastic packaging.

NB: stacking packages on the mobility support systems is strictly prohibited.



Stacking packages weighing over 60kg/m² is strictly prohibited, irrespective of their position.

2. STORAGE CONDITIONS

The mobility support system must be stored at a room temperature of between -10°C and +50°C, and relative humidity of between 30% and 75%.

Atmospheric pressure between 700hPa and 1060hPa under the same conditions as for transporting.

3. ASSEMBLY CONDITIONS

Only WINNCARE beds listed below are compatible with SAMs :

Bed reference	SAMs reference	Bed reference	SAMs reference
IAL1L*	A614/A615-00 A618/A619-00 A628/A629-00	IEX1L	A614/A615-00 A618/A619-00 A628/A629-00
IAL2L*	A614/A615-00 A618/A619-00 A628/A629-00	IEX2L	A614/A615-00 A618/A619-00 A628/A629-00
IAL3L*	A614/A615-00 A618/A619-00 A628/A629-00	IEX3L	A614/A615-00 A618/A619-00 A628/A629-00
IAL4L*	A614/A615-00 A618/A619-00 A628/A629-00	IEX4L	A614/A615-00 A618/A619-00 A628/A629-00
IAL5L / AL5*	A647/A648-00 A649/A650-00 A651/A652-00	IEX5L	A647/A648-00 A649/A650-00 A651/A652-00
IXS1L	A614/A615-00 A618/A619-00 A628/A629-00	IMS1L-IMS2L	A614/A615-00 A618/A619-00 A628/A629-00
IXS2L	A614/A615-00 A618/A619-00 A628/A629-00	IMS3L / MS3	A647/A648-00 A649/A650-00 A651/A652-00
IXS3L	A614/A615-00 A618/A619-00 A628/A629-00	MS4	A647/A648-00 A649/A650-00 A651/A652-00
IXP1L	A614/A615-00 A618/A619-00 A628/A629-00	IML1L	A614/A615-00 A618/A619-00 A628/A629-00
IXP2L	A614/A615-00 A618/A619-00 A628/A629-00	IML2L / ML2	A647/A648-00 A649/A650-00 A651/A652-00
IXP3L	A614/A615-00 A618/A619-00 A628/A629-00	IAE1L	A614/A615-00 A618/A619-00 A628/A629-00
IXP4L	A647/A648-00 A649/A650-00 A651/A652-00	IAE2L / AE2	A647/A648-00 A649/A650-00 A651/A652-00
IXX1L	A614/A615-00 A618/A619-00 A628/A629-00	IAE3L / AE3	A647/A648-00 A649/A650-00 A651/A652-00
IXX2L	A614/A615-00 A618/A619-00 A628/A629-00	IAF1L / AF1	A647/A648-00 A649/A650-00 A651/A652-00
IXX3L	A647/A648-00 A649/A650-00 A651/A652-00	IAF2L / AF2	A647/A648-00 A649/A650-00 A651/A652-00
IXA1L / XA1	A647/A648-00 A649/A650-00 A651/A652-00	IAX1L / AX1	A647/A648-00 A649/A650-00 A651/A652-00
IXB1L / XB1	A647/A648-00 A649/A650-00 A651/A652-00	IDO1L	A614/A615-00 A618/A619-00 A628/A629-00
IXL1L	A614/A615-00 A618/A619-00 A628/A629-00	IDO2L	A614/A615-00 A618/A619-00 A628/A629-00
IXL2L	A614/A615-00 A618/A619-00 A628/A629-00	IDO3L	A614/A615-00 A618/A619-00 A628/A629-00
IXL3L	A614/A615-00 A618/A619-00 A628/A629-00	IDO4L	A614/A615-00 A618/A619-00 A628/A629-00
IXL4L	A647/A648-00 A649/A650-00 A651/A652-00	IDO5L	A647/A648-00 A649/A650-00 A651/A652-00
IXN1L / XN1	A647/A648-00 A649/A650-00 A651/A652-00	IDO6L	A647/A648-00 A649/A650-00 A651/A652-00
IXO1L	A614/A615-00 A618/A619-00 A628/A629-00	IDO7L	A647/A648-00 A649/A650-00 A651/A652-00
IXO2L	A614/A615-00 A618/A619-00 A628/A629-00	IDO8L / DO8	A647/A648-00 A649/A650-00 A651/A652-00
IXO3L / XO3	A647/A648-00 A649/A650-00 A651/A652-00	AG1 / AH1	A647/A648-00 A649/A650-00 A651/A652-00

* ≥ if height less than 240 mm

MSSs are delivered folded up.



The mobility support system is intended to be used on 2,000 mm long WINNCARE beds with a square tube frame of no more than 40 mm.

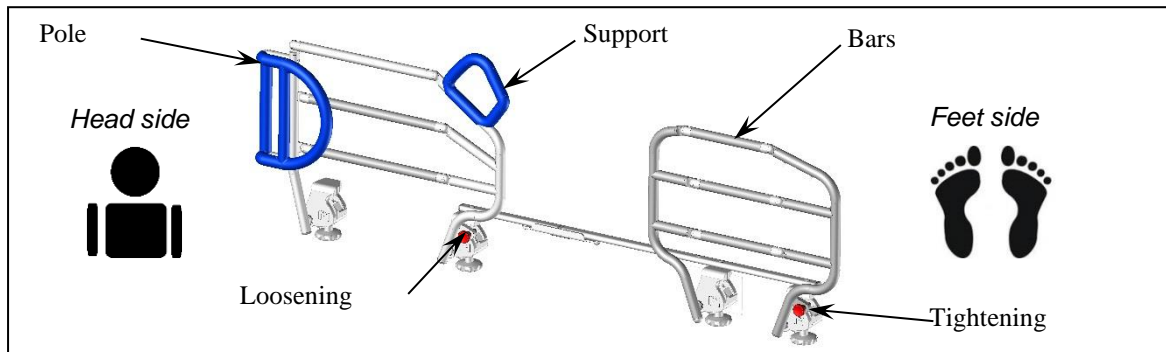

3.1. Assembling of the siderails A614-00/A615-00 A618-00/A619-00 A628-00/A629-00

The mobility support system is marked left and right by the grip jaws. Position the grip jaws as shown in the diagrams below.

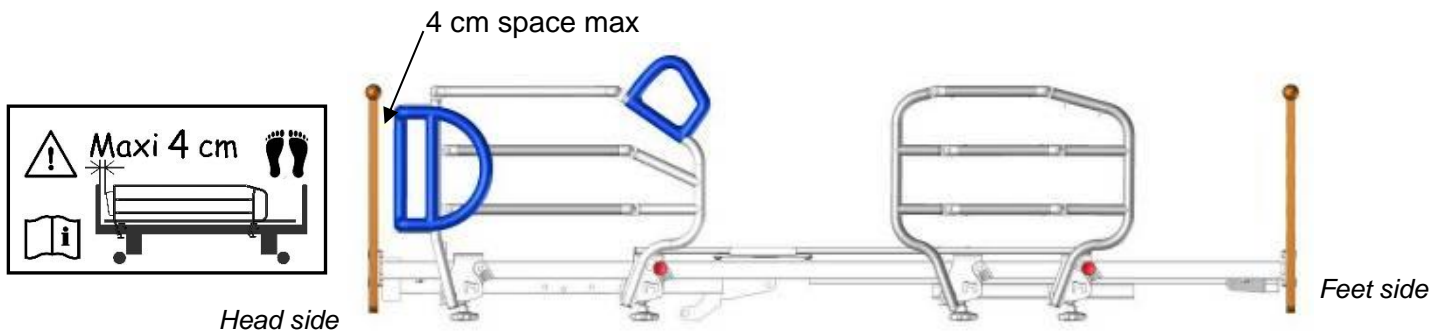

In order to assemble them on the bed, the longest section on the head end must be positioned by tightening the two adjustment knobs under the grip jaws. Then unfold the last one towards the foot end and tighten the knobs. Check that they are well locked.

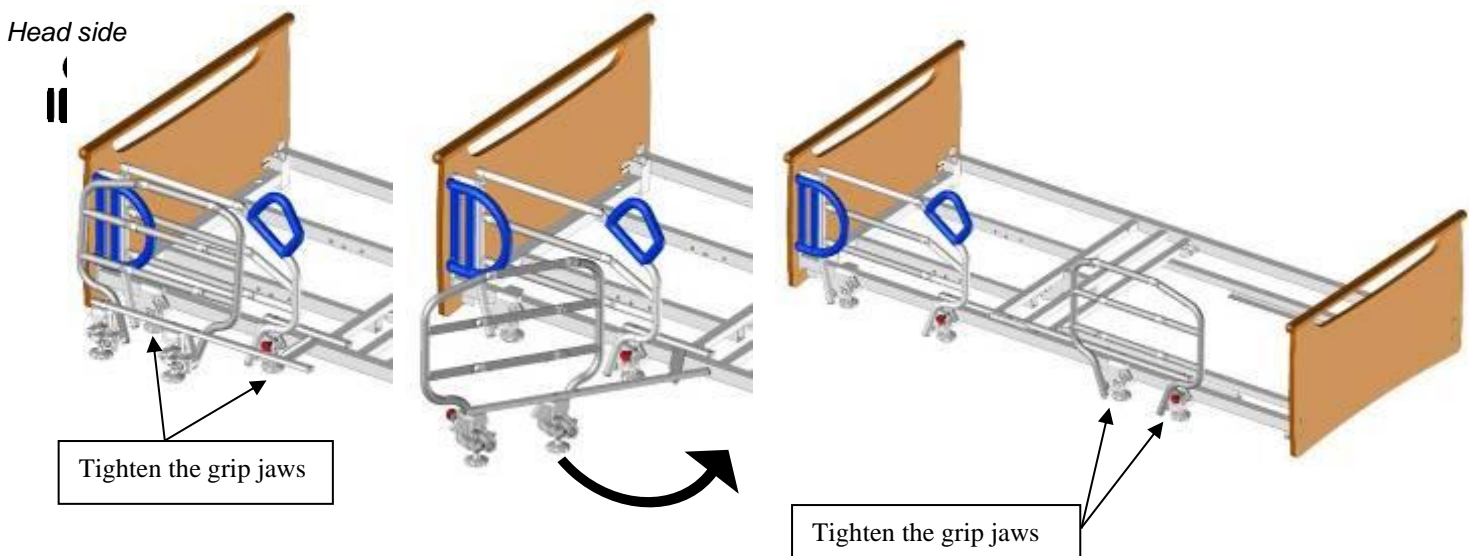

3.2. Assembling of the siderails A647-00/A648-00 A649-00/A650-00 A651-00/A652-00

Fixing jaw on the bed if it is not already installed, for this :

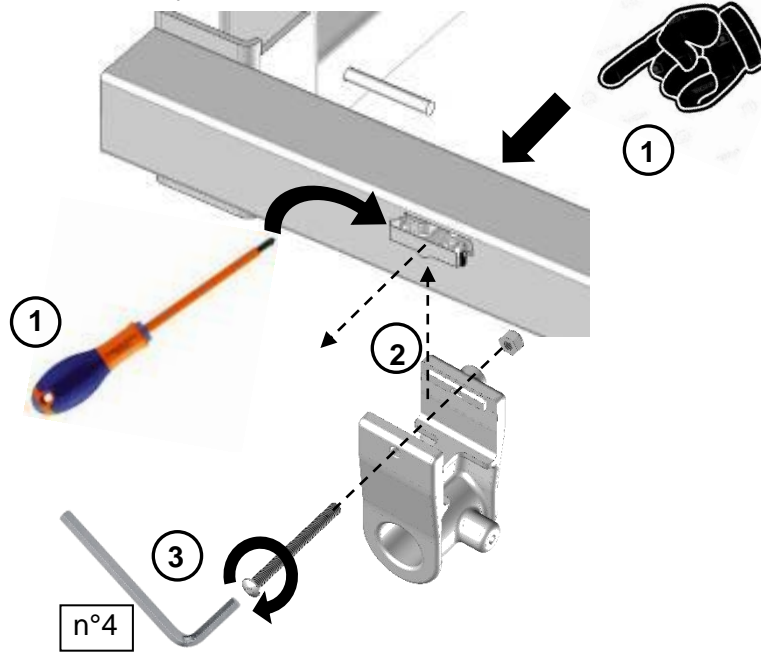

- ① Remove the cap of the siderail by pushing inside or outside (depending on the assembly) then remove it with a screwdriver if necessary.
- ② Clip the jaw in the slots provided for this purpose, by positioning the nut on the inner side of the bed.
- ③ Screw the jaw with the screw and nut provided with an Allen wrench n°4.

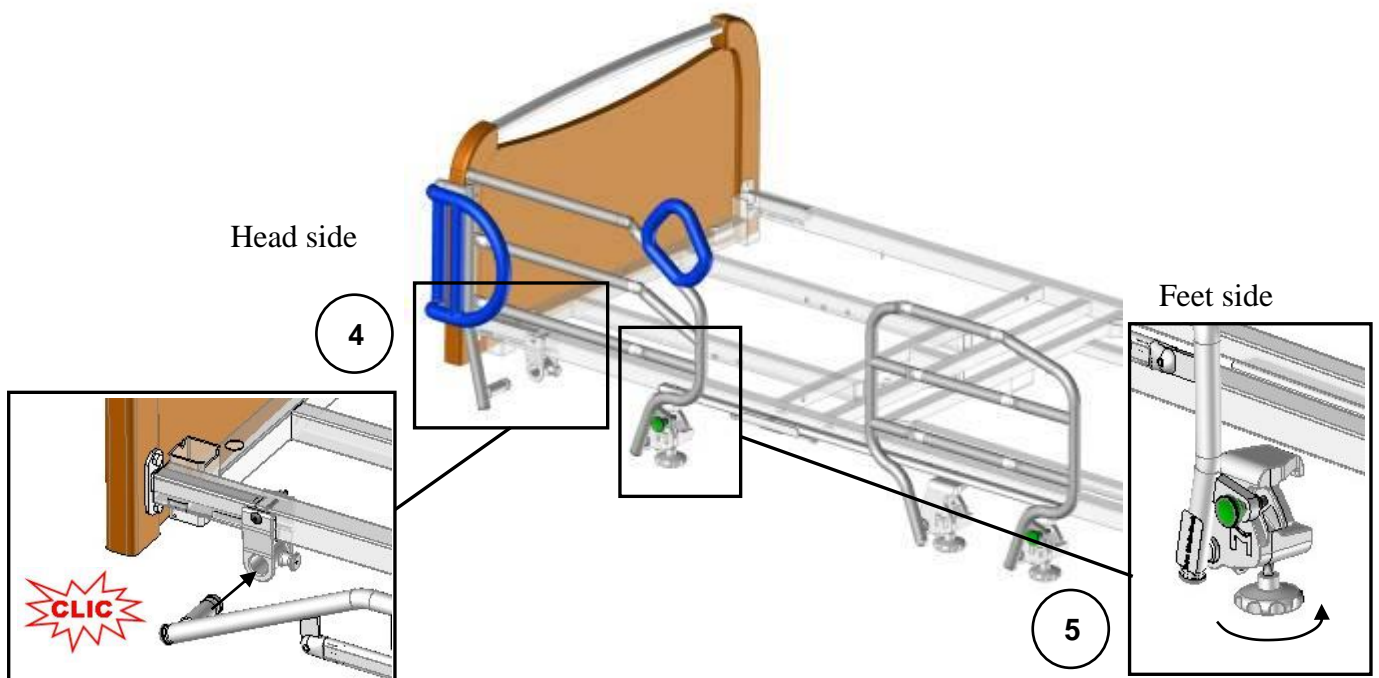

④ Insert the pole of the side rail in the jaw on the head side fixed on the bed until to hear the «CLIC»

⑤ Lock the jaw on feet side through the clamping rondo and ensure its blocking.

To remove the siderail, loosen the rondo on the feet side ⑤ then disengage the pole without removing it

by pulling the index finger on the side of the head side jaw ④. Take the side rail with one hand at each end to remove it completely.

4. CONDITIONS FOR USE

4.1. Function

The mobility support system (S.A.M.™) helps people to be independent.

The mobility support system is designed to prevent patients from falling while asleep or being transported BUT are not designed to prevent a patient from leaving his or her bed voluntarily. Many accidents happen when the patient tries to leave his or her bed despite the mobility support system being in place.

In some cases, the mobility support system helps to prevent falls, BUT it can pose a hazard: injuries, falling after trapping a limb in the mobility support system, suffocation after trapping the head, neck or chest. A risk/benefit assessment should preferably be carried out of the mobility support system to decide whether or not to use it.

This assessment must take the following into account:

- the department's surveillance capacities: A standardized protocol of the establishment for using the mobility support system may be drawn up.
- the physical and mental condition of the patient: his/her needs, capacities, lucidity, size, agitation. This assessment should be repeated at regular intervals.

➤ To lower the mobility support system.

- 1 Take hold of the half mobility support system by the top bar.

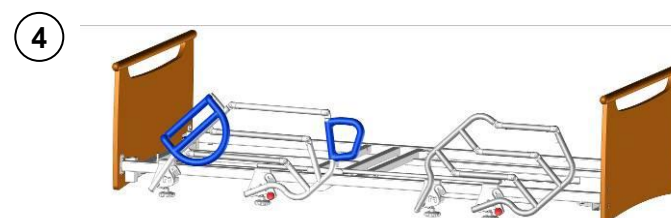
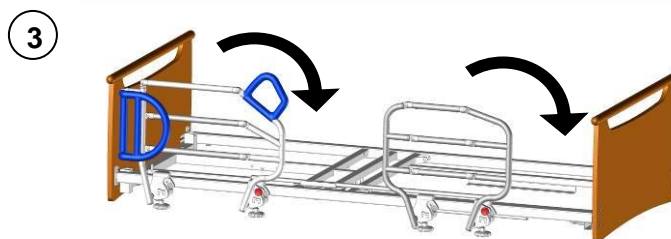
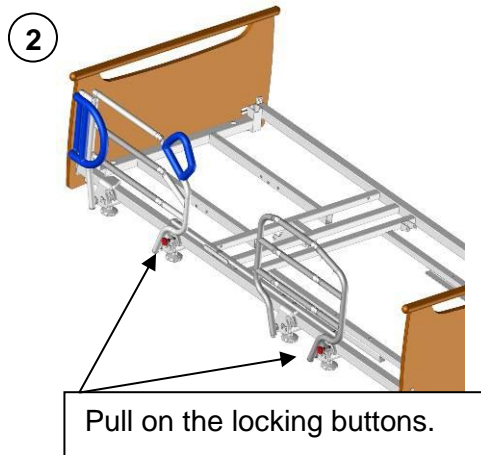

➤ To lift the mobility support system.

- 1 Take hold of the half mobility support system by the top bar and lift, making sure that the side handle is folded over the pole.

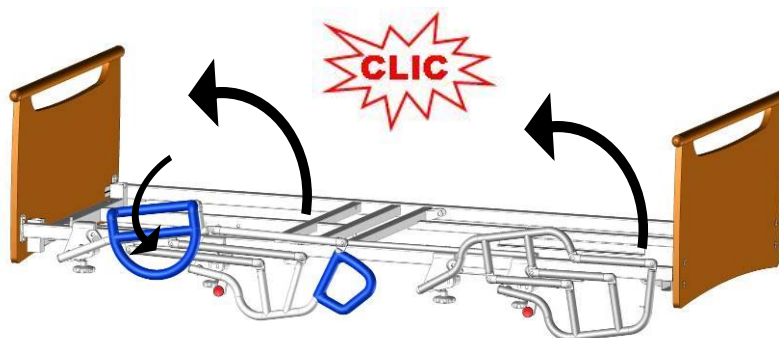

Make sure that the barrier is locked properly by attempting to fold it without acting on the unlocking finger

4.2. Use

To sit, take the upper part of the handle of the SAM by the opposite hand and then bring the other hand to the lower bar of the handle. A 'natural' movement causes the leg opposite the SAM to move towards the exit of the bed when you pull toward you with your arms the handle of the SAM.

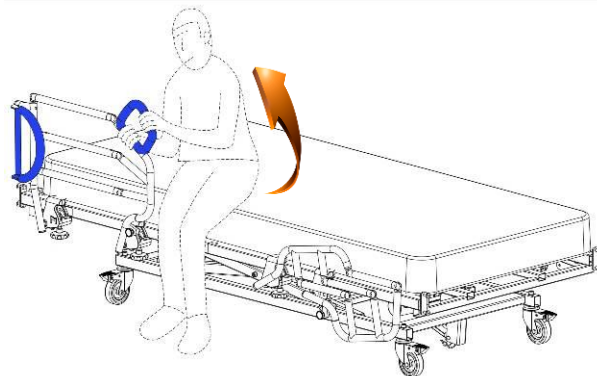
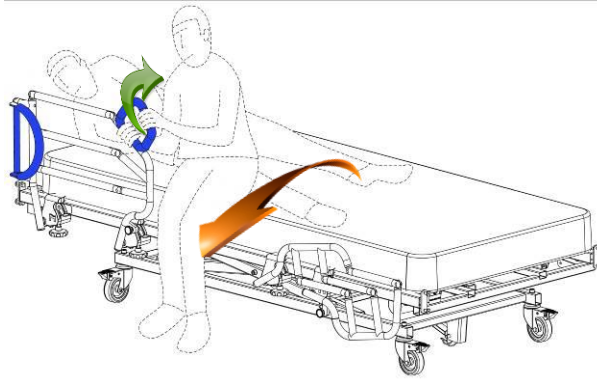
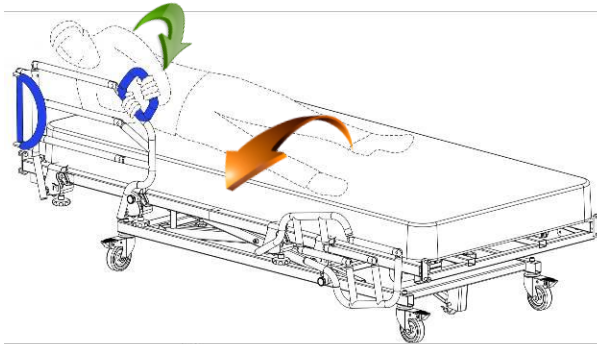

The turning handle is raised only when the barrier is folded back. It allows the patient to remain during the care of the caregiver.

The patient assisted by the caregiver catches the handle (1) by the opposite hand and rotates the pelvis (2) and thus maintains the vertical.

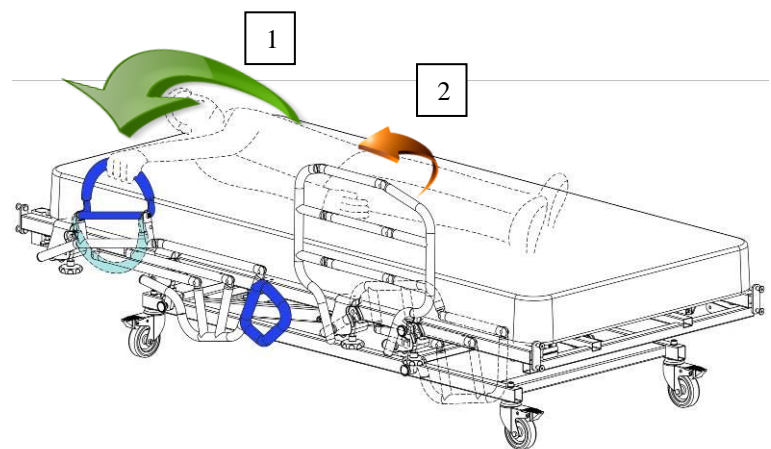

4.3. Precautions for use



Positioning the mobility support system poorly may undermine safety and cause a malfunction. The mobility support system **must not be used when patients are not adults or are ≤ 146 cm tall.**



The user and staff must be trained and aware of the risks associated with using the bed. He must not allow it by children and be vigilant when used by confused or disoriented people.



There must be at least 220 mm between the top of the side rail and uncompressed and no therapeutic mattress surface. It will be advisable to tend towards this specification in the case of the use of a therapeutic mattress.

Use of the mobility support system **A614-00/0001, A615-00/00001, A647-00/0001 and A648-00/0001** is not compatible with a bed base extension, panels Louis Philippe and does not allow for the use of accessory holders under the bed base. On some **XL and DUO beds 120/140/160**, you may have to remove accessory holders.

When stretching, fold the handle on the upright and make sure not to rub the side handle along vertical walls. When the bed is placed in low position, ensure that nothing or no area of the patient's or carer's body is between the bed, boards, accessories and floor.

The mobility support system must be used by someone outside of the bed, who must ensure that nothing or nobody is situated in the area in which the bed is being used.

The mobility support system is a medical device, and in this regard we inform you that it must not be modified under any circumstances. You must ensure its traceability. If you assemble different types of medical devices, you are responsible for conducting the risk analysis and making the CE declaration.

For assistance, if necessary, in mounting, operation or maintenance or to report unexpected operation or events, call your supplier or Winnicare.



Only use original parts and accessories distributed by **WINNCARE** to guarantee safety and maintain product conformity.

4.4. Residual risks

DANGER	RESULT	REQUIREMENTS FOR THE USER
Trapping	Hands pinched	Handle barrier by the upper bar
Trapping	Crushing body or object	Check before lowering the barrier that the movement area is free

5. MAINTENANCE CONDITIONS

5.1. Identification

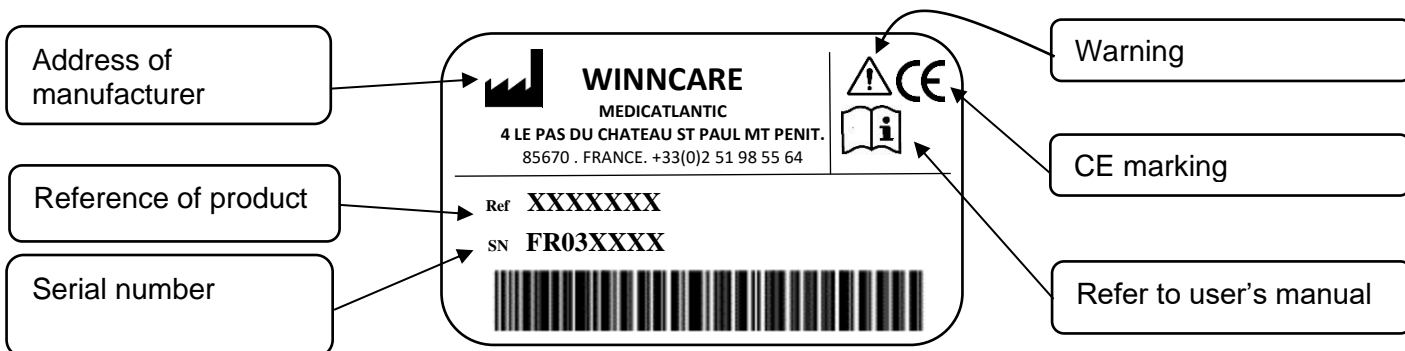

5.2. Upkeep

A detailed examination must be carried out on the mobility support system at least once a year on such parts as: the adjustment Rondo screws, index pins, pins and rivets.

5.3. Cleaning

Clean the structure with soapy water and a soft cloth then rinse and wipe dry. All aggressive or scouring products such as detergents, powders, solvents and bleach are prohibited

5.4. Disinfection

The Mobility Support System is a non-critical device justifying “Low-level” disinfection. We draw your attention to the fact that the instructions below are given in compliance with good practice recommendations but do not constitute protocol. Consult the hospital’s hygiene department.

5.4.1. Objective

Return the MSS to its original condition and prevent the transmission of germs from one patient to the next.

Get rid of any organic dirt through:

Mechanical action (cleaning)

Chemical action (disinfection)

5.4.2. Indication

Physical and bacteriological cleanliness of the MSS

5.4.3. Equipment

Microfibre wipes

Detergent or Detergent-Disinfectant (Surface DD° with CE marking and Surface Disinfectant) (Chlorinated derivatives, alcohol base < 30%)

NB: DD products and bleach must not be used neat. Persistence time must be applied according to the disinfectant manufacturer (drying time often equals the persistence time excluding human presence)
SANIVAP type steam device with accessories

5.4.4. Technique

- Daily upkeep using a surface DD product applied in one go.
- Upkeep once the patient leaves or periodically via the *Bio cleaning* process which involves 3 operations:
 - o Cleaning is done using a cloth soaked in a detergent solution or surface Detergent-Disinfectant (DD)
 - o Rinsing is done using a cloth rinsed in clean water
 - o Disinfection is done using a cloth soaked in a surface disinfecting solution.
- Specific upkeep by the service providers once the MSS has been removed from the establishment.
 - o Get rid of the packaging after decontamination of the inside by DD solution spray
 - o *Bio cleaning* process, or,
 - o Steam cleaning (accessory with microfibre strip) of the various flat surfaces and bed base slats. Change washing mops at regular intervals to prevent any aqueous build-up. Clean any parts that are difficult to access (casters, joints once they are open, corners, etc.) using a steam nozzle. For the tubes, use the steam nozzle with a microfibre cloth. Do not point the nozzle straight on to electric casing or actuators.
 - o Dry joints with compressed air
 - o NB: Disinfect jacks, electric casing and remote controls using a microfibre cloth soaked in disinfectant.

Do not rinse or wipe dry.

Inspection that the various functions of the MSS are in good working order.

Repairs if necessary

Packaging of the MSS with heat shrink wrap

NB:

- Apply the measures recommended by the hospital hygiene department in the event of additional precautionary measures (Contact precautions, Drops, Air)
- Use of a bleach solution stronger than 5,000ppm (0.5% of active chlorine) must be justified by microbiological risk and applied for the length of time necessary (Risk of ageing of certain materials over time – particularly colour).
- The concentration of alcohol-based surface disinfecting solutions must be less than 30%.

NB: use of the terminal disinfection procedure is compatible with the medical bed and its accessories.

- Isolate the mobility support system in a disinfection room equipped with a particle filtering system and disposal for washing the floors and walls after disinfection.
- Use a disinfectant with bactericidal, fungicidal and virucidal properties, either by spraying it evenly onto surfaces, applying it with a disposable cloth or spraying a disinfectant aerosol from a distance of 30 cm.

NB:

Comply with the precautions for using disinfectants indicated on these products.

Leavy to dry and protect the disinfected equipment from other equipment that has not been disinfected by a film and a label indicating the disinfection date.



Product for external use only. Do not swallow. Store in a cool place and avoid contact with eyes.

5.5. Lifetime

The lifetime under normal conditions of use and maintenance is 5 years for accessories, especially for Mobility Support Systems.

5.6. Warranties

- All of our products carry a warranty against any manufacturing defect, provided the normal conditions for use and maintenance are complied with.
- Labour costs due to changes in structures or parts under warranty are not taken into account.
- Please refer to the standard terms of sale for the specific terms of warranty for each product.
- Every time you contact us for possible maintenance, you must quote us the information on the MSS identification label and on the jack body, if this is concerned.
- Original parts shall be supplied for replacement, within the term of warranty, by our customer sales network determining the beginning of the term of warranty.
- Defective parts must be returned to ensure proper application of this warranty and also to avoid any invoicing.

6. CONDITIONS FOR SCRAPPING

- The product must be scrapped if the main requirements are no longer met, particularly when the product no longer has its original characteristics and has not been subject to corrective action during the manufacturing process.
- Measures should therefore be taken to ensure that the product is no longer used for the purpose it was originally intended.
- When scrapping, the current environmental standards must be complied with.

WINCARE

F r a n c e

4 Le Pas du Château
85670 SAINT PAUL MONT PENIT
TEL : +33 (0)2.51.98.55.64
FAX : +33 (0)2.51.98.59.07
Email : info@medicatlantic.fr
Site Internet : <http://www.winnicare.fr>